

PART NUMBER	PLATING
0409-06 M1-D	.000300 CADMIUM/.000080 NICKEL
0409-06 M1-K	BLACK CHROME
0409-06 M1-N	Ni/Cu

PLATING PER SAN-TRON SPEC. 7.3.1-8

- NOTES:
1. TENSILE STRENGTH 45 LBS. MINIMUM.
 2. EYELETS: STAINLESS STEEL 303
 3. RIVETS: STAINLESS STEEL 340
 4. WASHER: STAINLESS STEEL 303
 5. WIRE ROPE: MIL-W-83420, 1/32 CORROSION RESISTANT STEEL, DARK OPAQUE NYLON JACKETED, TYPE II, COMPOSITION B.
 6. ALL OTHER METAL: BRASS
 7. GASKET: SILICONE RUBBER
 8. PLATING: SEE TABLE
 9. TEMP RANGE: -75 °F TO 450 °F

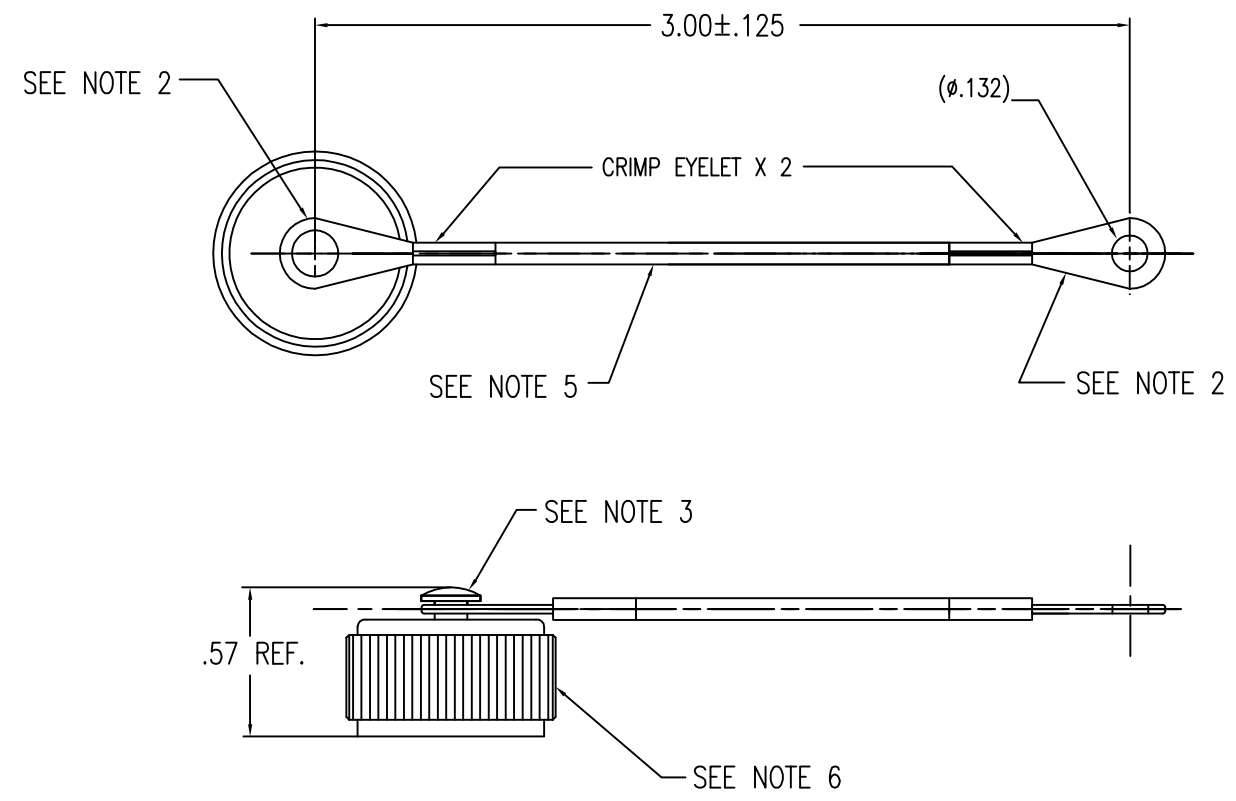

Rev.	Revisions	Date	Dwn.	Appd.
B	ADD PLATING CODE N, UPDATE NOTES	4/25/18	ST	
B	NOTE 1 CHANGE: WAS 75 LBS MIN	10/17/17	ST	FSH
A	ORIGINAL	8/16/12	<input checked="" type="checkbox"/>	<input checked="" type="checkbox"/>
STOCK	FT/M PCS	QTY REQD		
STOCK	FTM	QTY		

PROPRIETARY
 THIS DRAWING CONTAINS CONFIDENTIAL INFORMATION PROPRIETARY TO SAN*TRON INC. IT MUST NOT BE REPRODUCED OR DISCLOSED TO OTHERS OR USED IN ANY OTHER WAY, IN WHOLE OR PART EXCEPT AS AUTHORIZED IN WRITING BY SAN*TRON INCORPORATED.

REMOVE ALL BURRS AND SHARP EDGES .005 MAX. UNLESS OTHERWISE STATED ALL DIMENSIONS ARE IN INCHES AND APPLY AFTER PLATING

UNSPECIFIED TOL.
 DEC. ± .005
 FRAC. ± 1/64
 ANG. ± 1/2'

CONCENTRICITY .004 TIR
 ALL MACHINED SUFACES

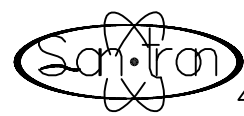

SAN • TRON, INC.

4 NEWBURYPORT TPK, IPSWICH, MA 01938

TITLE: N MALE CAP WITH JACKETED ROPE WIRE

MATERIAL: SEE NOTES FINISH: SEE NOTES

FSCM NO. 50896 DWG NO. OL-0409-06-1 M1 REV. C

DO NOT SCALE PRINT

63/ ✓