

PART NUMBER	PLATING
0409-06-D	.000300 OLIVE-DRAB CADMIUM OVER .000080 NICKEL
0409-06-K	BLACK CHROME

PLATING PER SAN-TRON SPEC. 7.3.1-8

NOTES:

- TENSILE STRENGTH 45 LBS. MINIMUM.
- EYELETS: STAINLESS STEEL 303
- RIVETS: STAINLESS STEEL 340
- WASHER: STAINLESS STEEL 303
- WIRE ROPE: MIL-W-83420, 1/32 CORROSION RESISTANT STEEL, DARK OPAQUE NYLON JACKETED, TYPE II, COMPOSITION B.
- ALL OTHER METAL: BRASS
- GASKET: SILICONE RUBBER OR VITON.
- PLATING: SEE TABLE

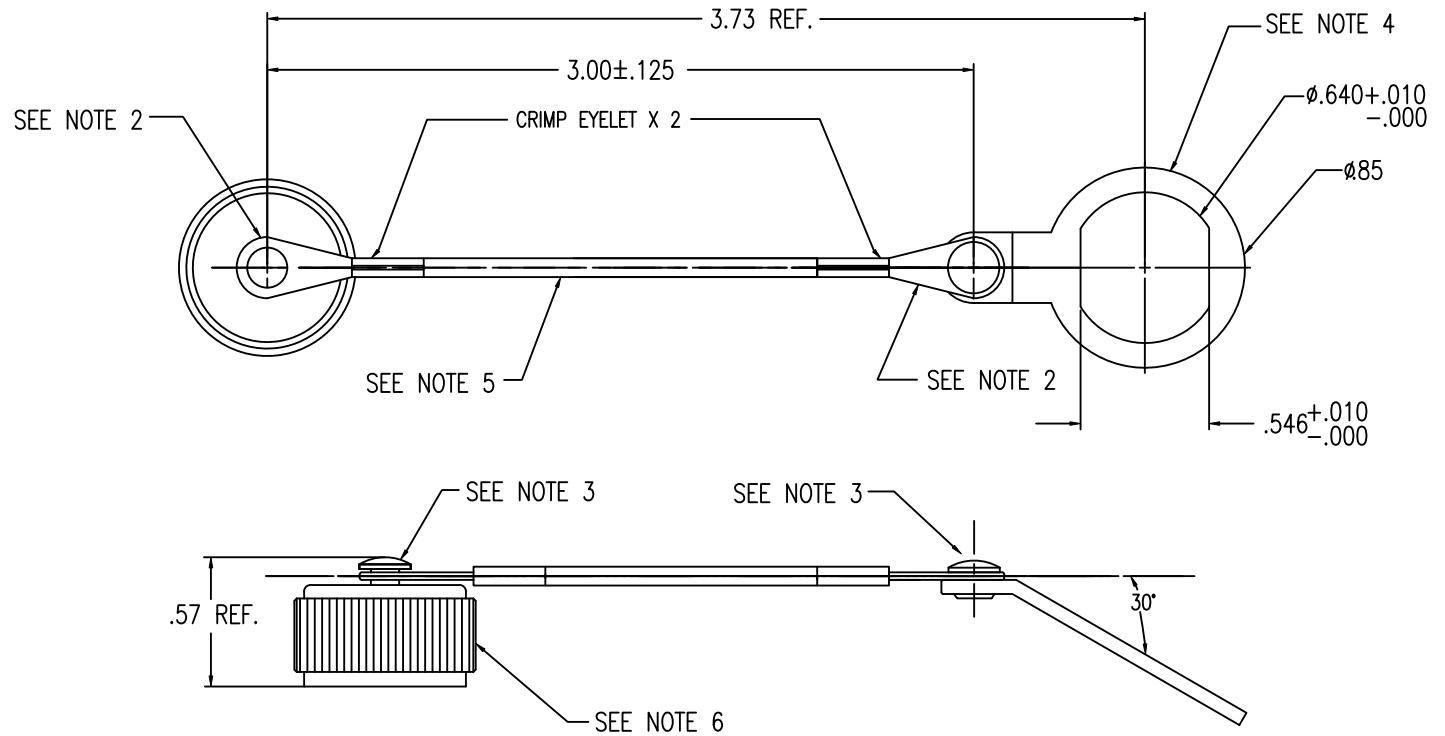

D1	CLARIFY OLIVE DRAB D PLATE	3/7/24	NBS	NBS
D	NOTE 1 CHANGE: WAS 75 LBS MIN	10/17/17	ST	FSH
C	UPDATED RIVET AND WASHER ALIGNMENT	1/8/09	JTH	FSH
B	ADD BLACK CHROME PLATE OPTION ADD PLATING TABLE	10/10/07	DVP	DVP
A	ORIGINAL	10/28/05		
Rev.	Revisions	Date	Dwn.	Appd.
STOCK	FT/M PCS	QTY REQD		
STOCK	FTM	QTY		

PROPRIETARY
THIS DRAWING CONTAINS CONFIDENTIAL INFORMATION PROPRIETARY TO SAN*TRON INC. IT MUST NOT BE REPRODUCED OR DISCLOSED TO OTHERS OR USED IN ANY OTHER WAY, IN WHOLE OR PART EXCEPT AS AUTHORIZED IN WRITING BY SAN*TRON INCORPORATED.

REMOVE ALL BURRS AND SHARP EDGES .005 MAX.
UNLESS OTHERWISE STATED ALL DIMENSIONS ARE IN INCHES AND APPLY AFTER PLATING

UNSPECIFIED TOL.	DWN	DVP	10/28/05
DEC. ± .005	CHKD	SJS	x
FRAC. ± 1/64	APPR	FSH	10/28/05
ANG. ± 1/2°			

CONCENTRICITY .004 TIR
ALL MACHINED SUFACES

SAN • TRON, INC.
4 NEWBURYPORT TPK, IPSWICH, MA 01938

TITLE: N MALE CAP WITH JACKETED ROPE WIRE

MATERIAL: SEE NOTES FINISH: SEE NOTES

FSCM NO. 50896 DWG NO. OL-0409-06-1 REV. D

DO NOT SCALE PRINT